

# L10

arrayable full range loudspeaker

quint audio L10 manual 1.2/en

## L10 manual

1x10"/2x1.75" Line Source Module  
Operating & Rigging Instructions



Thank you for purchasing the Quint Audio L10 Enclosure.

This manual contains essential information on installing and operating the product correctly and safely. It is necessary to read this manual carefully in order to become familiar with these procedures.

Keep the manual for future use. This manual forms an integral part of the product. Reselling of the product is only possible if the user manual is available. Any changes made to the product must be documented in writing and passed on to the buyer in the event of resale.

As part of a continuous evolution of techniques and standards, Quint Audio BV reserves the right to change the specifications of the product and the content of this manual without prior notice. Please check the Quint Audio BV web site at [www.quintaudio.com](http://www.quintaudio.com) on a regular basis for any updates.

Should the product require repair or should information about the warranty be needed, please contact an approved Quint Audio BV distributor. The address of the nearest distributor is available on the Quint Audio BV web site.

### Unpacking

Carefully open the shipping carton and check the product for any noticeable damage.

Each Quint Audio BV product is tested and inspected before leaving the factory and should arrive in perfect condition. If found to be damaged, notify the shipping company or the distributor immediately.

Only the consignee may initiate a claim with the carrier for damage incurred during shipping. Be sure to save the carton and packing materials for the carrier's inspection.



### Safety Warnings in this manual

This refers to potentially dangerous situations or dangerous forces that may lead to personal injury.



This refers to a potentially dangerous situation which may lead to damage to the equipment.



This refers to a situation which may cause the equipment to malfunction.



**Read this manual carefully before using the product.**

- Read all safety instructions, warnings and instructions concerning this product.
- Make sure you fully understand the safety issues mentioned.
- Read all cautions present on the product itself.
- Read all the related product information before using the system.
- Work with qualified personnel only.
- Rigging, hoisting and flying equipment is never free of potential hazards. You cannot rule out human error while gravity, wind and electrical forces do their regular job. Therefore: Always use your common sense!

**Personal safety**

Ensure health and safety during installation and setup. In order to prevent accidents when deploying loudspeakers on the ground or when flown, please take note of the following:

- The system may not be used for other purposes than it is meant for.
- All system components must be inspected before use, in order to detect any possible defects.
- Take into account the wind effects on dynamic load. When a loudspeaker assembly is deployed in an open air environment, wind can produce dynamic stress to the rigging components and suspension points. If the wind force exceeds 6 Beaufort scale, lower down and/or secure the loudspeaker array.
- Be cautious when flying a loudspeaker array. Always verify that no one is standing underneath the loudspeaker array when it is being raised or lowered.
- As the array is being raised, check each individual element to make sure that it is securely fastened to the adjacent element.
- Never leave the array unattended during the installation process. As a general rule Quint Audio advises the use of safety slings at all times.
- Do not place the product on an unstable cart, stand, tripod, bracket, or table. The product may fall and be seriously damaged and may cause serious human injury.
- Loudspeakers and amplifiers work with potentially harmful voltages. Avoid any direct contact with the human body. Respect electrical safety warnings at all times.
- Use certified connectors and cables. All cables must be electrically safe (according to NEN1010) and routed so that there is no direct walking on an/or driving over it nor objects are placed on top of them in any way it might damage the cable. Make sure that the cables and connectors are used stress free.

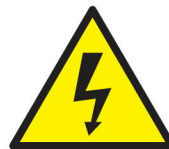

- All persons must wear protective headgear and footwear at all times.
- Under no circumstances personnel is allowed to climb into a loudspeaker assembly.
- Never stand in the immediate vicinity of loudspeakers driven at a high SPL level. Professional loudspeaker systems are capable of causing a sound pressure level that is harmful to human hearing. Seemingly non-critical sound levels (from approx. 95 dB SPL) can cause hearing damage if people are exposed to it over a long period of time.



### General mounting and rigging instructions

- Respect the Working Load Limit (WLL) of Quint Audio equipment at all times.
- Respect the WLL of third party equipment at all times.
- Quint Audio is not responsible for any rigging equipment and accessories provided by third party manufacturers.
- Respect the maximum configurations and the recommended safety level (please use Quint Audio's WLL-calculator).
- Verify that the WLL of the suspension points, chain hoists and all additional hardware rigging accessories are respected.
- The system should only be installed or fitted in accordance with the manufacturers recommendations.
- Installation should only be carried out by qualified personnel who are familiar with and have knowledge of the rigging techniques used and with the safety recommendations stated in this and other eventually related manuals.



### Conditions which require immediate service

In all cases, when after an event risk of unsafe operation of the device, such as:

- After the damaged hitting any casing or cable.
- After a fall from the product resulting in visible or invisible damage.
- After mishaps and/or misuse and or possible visible or invisible deformation of any rigging system, rigging part or rigging accessory.
- After noticing a change in the operation of the device.
- After the product has been exposed to rain or moisture.
- After the product has been exposed to foreign objects or liquids.

### Magnetic field

Loudspeakers produce a static magnetic field even if they are not connected or are not in use. Therefore make sure when managing and transporting loudspeakers, they are nowhere near equipment and objects which may be impaired or damaged by their external magnetic field. Generally speaking, a distance of 0.5 m (1.5 ft) from magnetic data carriers (floppy disks, audio and video tapes, bank cards, etc.) is sufficient; a distance of more than 1 m (3 ft) may be necessary with computer and video monitors.

### Product monitoring, care and maintenance

- If applicable please refer to this manual as well as to the "rigging manual" as any other manuals pertaining to the system for a detailed description of the inspection procedure.
- Regularly check all load bearing bolts and other metal parts in the mounting devices. Any parts showing any sign of (suspected) defect must immediately be put aside and withdrawn from use to be inspected by qualified service personnel.
- Regularly check the loudspeaker housings and accessories for visible signs of wear and tear, and replace them when necessary.
- Keep the loudspeakers away from heat producing sources such as heaters, stoves, fireworks etc. etc.
- Keep the loudspeakers away from water; prevent the possibility of water and moisture entering it.
- Even if the product is weather-resistant, it should not be exposed to moisture (rain, sea spray, shower, steam) for a long period of time, nor put in direct contact or immersed in water.
- Prevent objects and/or any liquid to enter the device.
- The loudspeaker housings can be cleaned with a damp cloth. Do not use aggressive cleaning agents or solvents as they can damage the protective layers.
- Small damages can be repaired with a water-based paint such as Warnex textured paint. The base layer however is an environmentally friendly polyurea. Damage to this layer can be repaired with polyurea, but this must be done by the manufacturer or a certified Quint Audio service point.
- The user should not carry out any work or maintenance on the system other than those mentioned in the manufacturers instructions. Technical service must be carried out by authorised technical personnel only.



## Design

The Quint Audio L10 is a 2x1"ND/10"ND 2-way actively filtered scalable full-range speaker system. The 10-inch neodymium woofer of the U10 is equipped with a demodulation-ring and features a 77 mm voice-coil which results in an improved thermal, impedantive and dynamic behavior of the loudspeaker.

Two 1"ND high frequency drivers are applied for the mid-high and high frequency range and feature multiple ring-phase plugs which ensure an increased phase purity. The light and durable polymer membranes are driven by 44 mm voice coils. The drivers are mounted on a specially designed dual wave guide, followed by a constant directivity horn with a precise opening angle of 80 degrees horizontally x 12 degrees vertically.

By design the components in the L10 are arranged asymmetrically, however due its the well defined wave shaping capabilities the cabinet produces an almost perfect symmetrical dispersion pattern. For perfect stereo imaging, the L10 cabinet comes in a left and right version.

The L10 is built of birch plywood and equipped with a wear-, tear- and impact-resistant hybrid coating. Various internal bracings and metal supports are applied in order to increase the rigidity of the design. The front is finished by a coated steel grille with an acoustically transparent layer. Each side panel incorporates a handle on the side and a handle at the rear.

The L10 features an arrayable rigging system and several external rigging accessories are available.

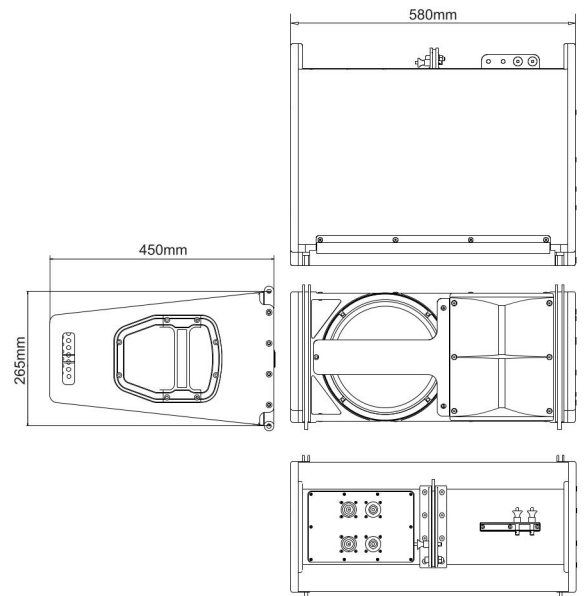

## Specifications & Measurements

type	10"/2x1,75" arrayable system
filter	bi-amplified
power handling	140W HF/550W LF
program power	280W HF/1100W LF
impedance	10 Ohms
sensitivity	97dB LF/107dB HF 1Wm
program SPL	128 dB 1m
frequency range	52 -20.000 Hz
dispersion	80°x12° h xv
weight	21 kg
size (wxhxd)	580 x 265 x 450 mm

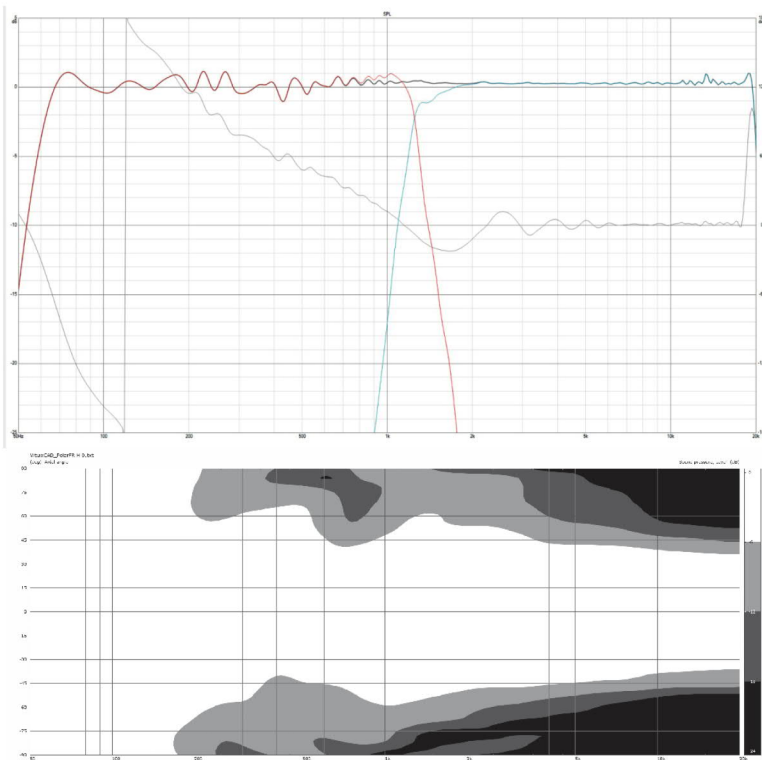

### Application

The Quint Audio L10 is a 1x10"/2x1,75" arrayable full range loud-speaker module designed for scalable vertical system setups in small to medium-sized PA applications. The system can easily be adapted to a desired coverage and to a desired SPL-demand L10 cabinets can be flown in vertical columns up to 24 cabinets (depending on the shape of the column, please use EASE Focus software to determine the size and form of the array and the Speaker Cluster Calculator to determine whether the workload is safe).

The L10 provides a 80° constant directivity dispersion pattern in the horizontal plane. The cylindrical wave segments of each cabinet couple without gaps and sum very coherently. Splay angles between adjacent cabinets can be set in the range from 0° to 12° in 1° increments.

The L10 module is mechanically compatible with the L16 which provides a 120° horizontal dispersion. The L16 cabinet is a 3-way design housing 2 x 8" neodymium LF drivers, one horn-loaded coaxial 4" MF/1 HF driver mounted to a dedicated wave guide. L10 cabinets are driven by two channels of the respective quint audio amplifier providing the active crossover between LF and HF.

The L10 is also suitable for stacking. This can be done with the aid of only the C1 module. For flying setups the C2 T-bar is connected to the C1 stacking frame so it becomes a complete rigging frame underneath which also subs can be flown.

The sub-extensions mentioned are the L-sub, L-low and L-bass. The L-sub functions as a genuine sub, while the horn-loaded L-low is more suitable as a real low-speaker. A combination of L-sub and L-low results in a very powerful bass foundation to L10 tops. The L-bass is an ideal compromise between L-bass and L-sub and is very suitable for broad and universal PA applications. More information in the L-low, L-sub and L-bass data.

In overview, the L10 is a very versatile and flexible system that is ideal for daily rental situations and fixed installations and plays a valuable role in the Quint Audio system range. The strong points of the L10 are its 'hifi' sound, full range capability and outstanding constant directivity.

24 cabinets in one string ((max. amount depends on the shape of the array))

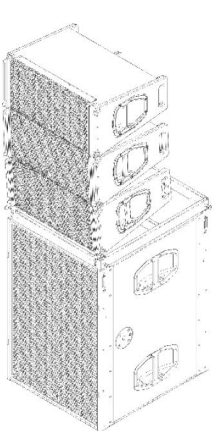
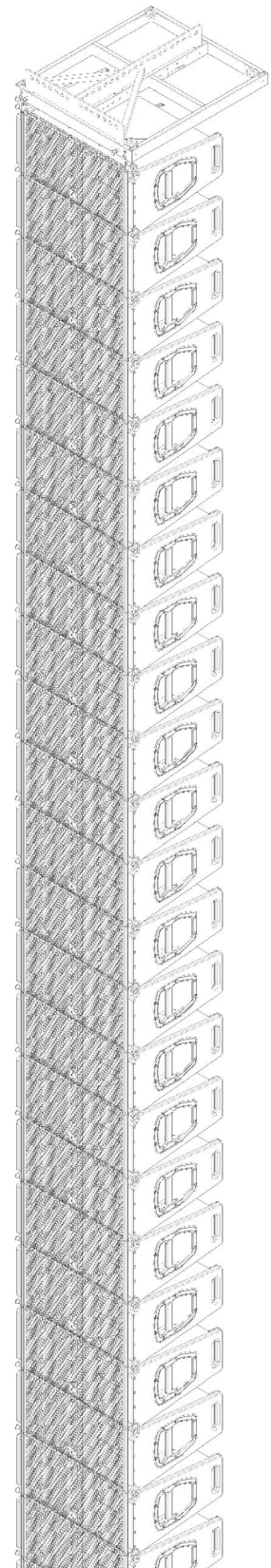

stacked

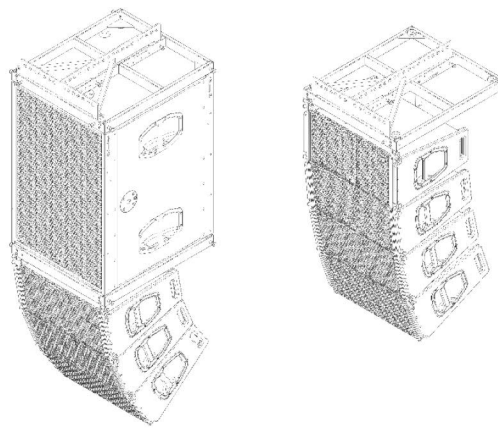

flying with and without bass cabinets

# L10

arrayable full range loudspeaker

## Connectors and internal wiring of the loudspeaker

The connection panel on the of the L10 cabinet is fitted with both a pair of Neutrik Speakon NL4 and NL8 connectors. All pins of both connectors are wired in parallel internally.

Internal connection between the NL4, the NL8 and the components:

- NL4 pin1+/1- is connected with NL8 pin 3+/3- = LF (low frequency)
- NL4 pin2+/2- is connected with NL8 pin 4+/4- = HF (high frequency)
- NL8 pin 1+/1- is designated to Quint Audio subs
- NL8 pin 1+/1- is designated to Quint Audio lows

Pin assignments are stated on the backpanel (layouts on the right).

The same connection panels are fitted on all other L-series tops. They offer a maximum flexibility in connection, conversion, looping and twisting without the need of cables and connectors that would otherwise need to be customized for a specific purpose.

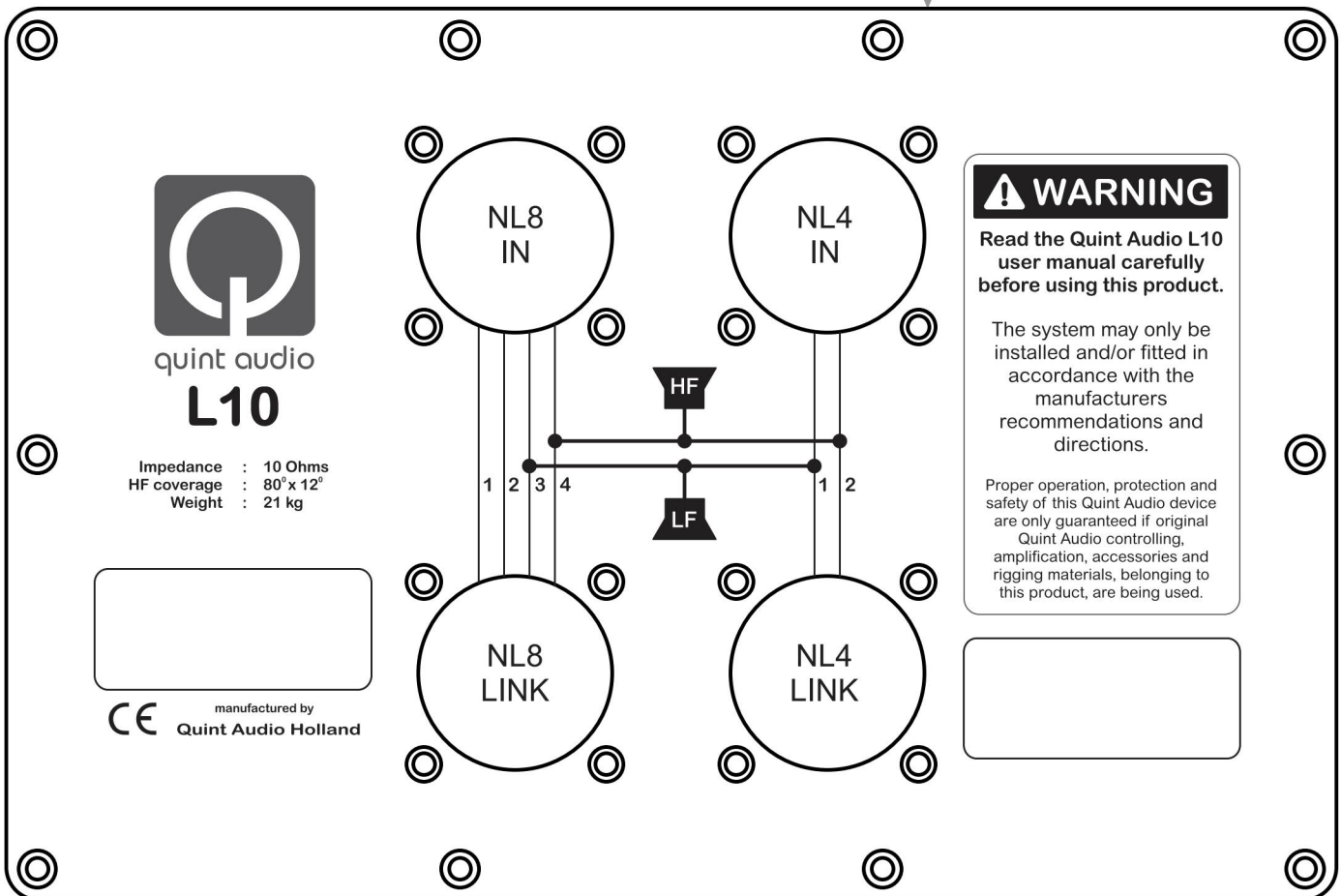



**Flying (& stacking) L10 with the C1 combi frame and C2 T-bar**

C1 cradle can be used in 4 different ways

- 1) stacking frame for tops
- 2) flying frame for tops
- 3) flying frame for subs
- 4) flying frame for a combination of subs and tops

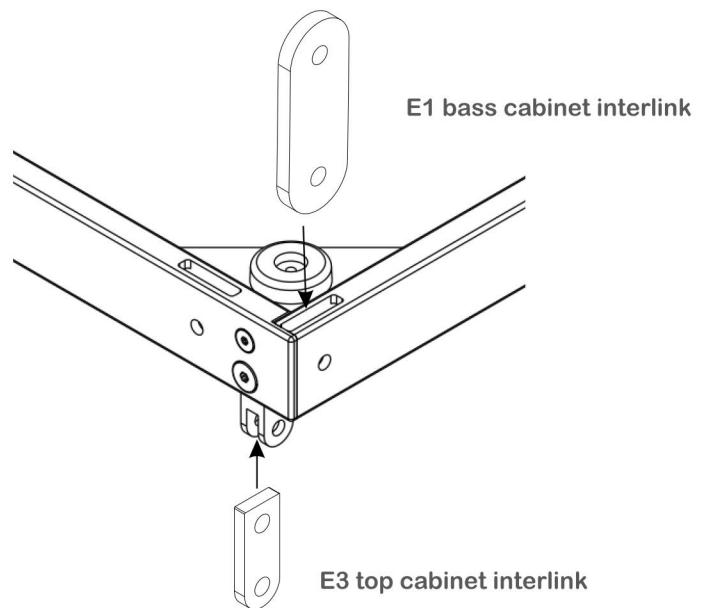
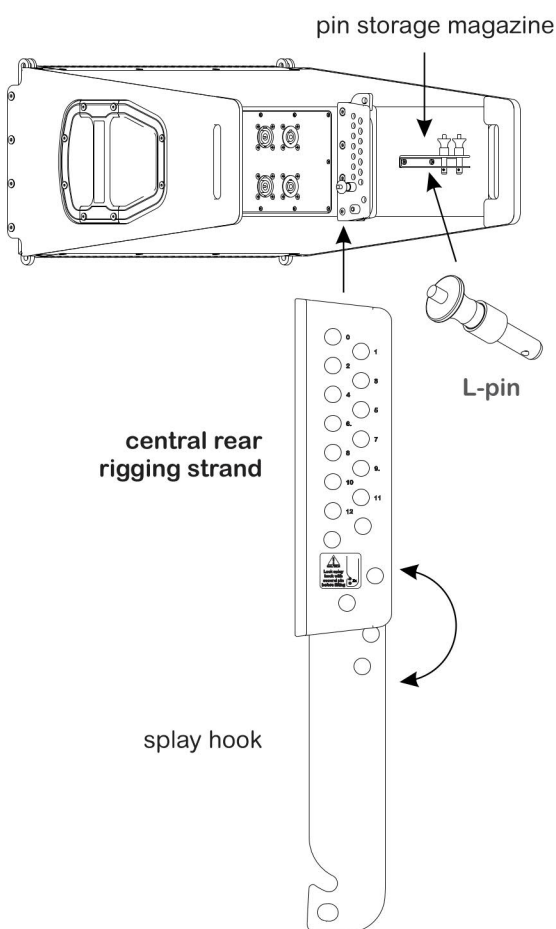
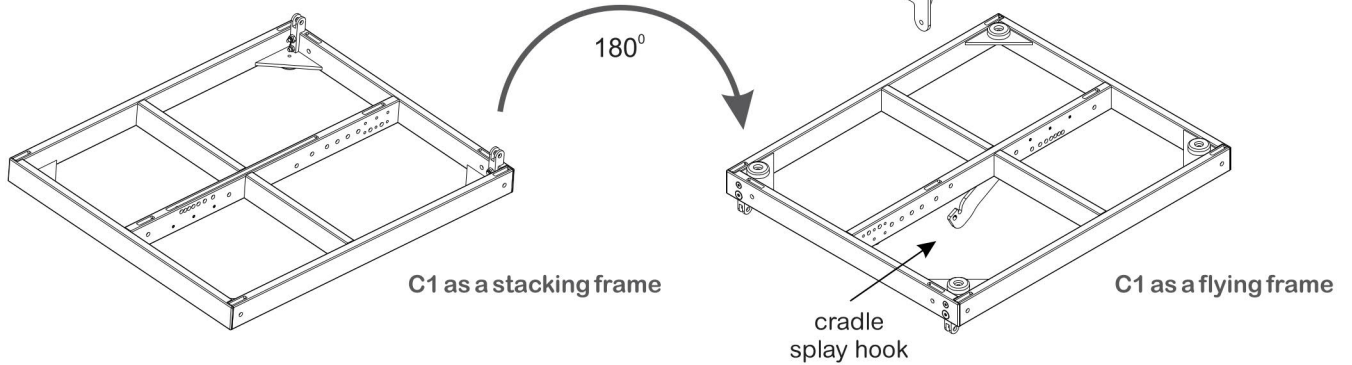
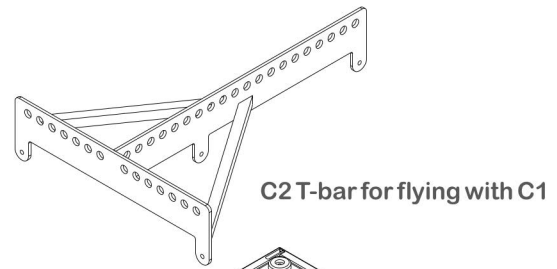

**Flying L10 with the C3 T-bar**

- C3 can be used in one way:
- 1) flying L-series tops

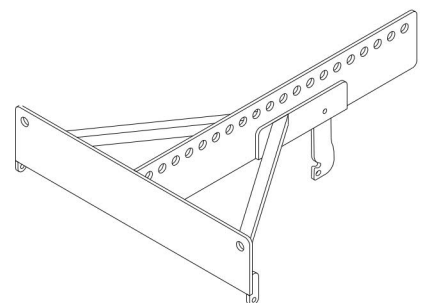

## The L10 rigging construction principle with C1 and C2

On the right you see a rigging construction consisting of C1 stacking/rigging frame and C2 rigging T-bar.

The flight system of the L10 is a so-called Tension Mode system in which the loudspeakers drop into a hook by their own weight during setup, after which they then are secured so the hook stays in place.

For transport, the hooks are unsecured so the speakers will gradually collapse at their maximum angle while lowering them into their trolley. (more about this further on in this manual)

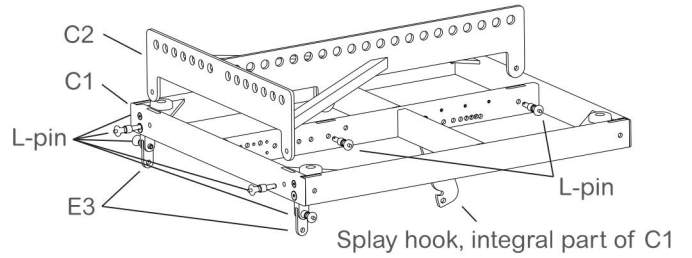

When the C1 cradle is used as a flying frame, the C2 T-bar must be mounted on top of it first.

Attach the front of the L10 to the C1 cradle by inserting an L-pin through the E1 on both sides. The E1's on their turn have previously been attached to the C1 using the same pins, as well as the C2 T-bar.

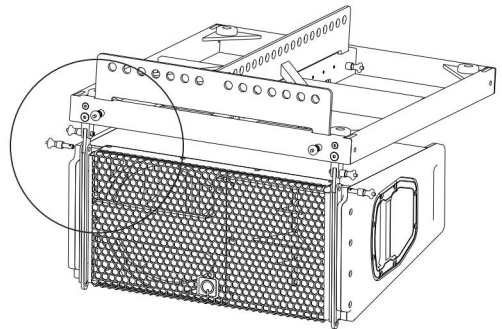
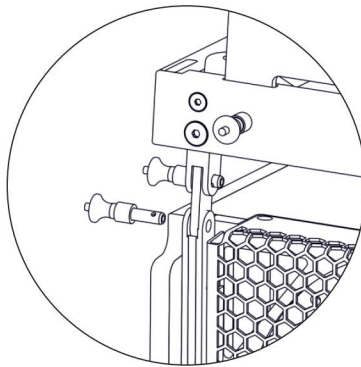

At the rear, place the first pin in the hole with the desired angle at which the L10 should hang from the cradle or the speaker hanging above it.

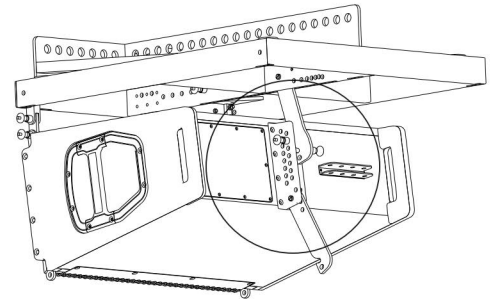
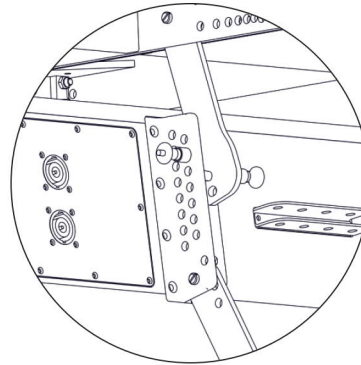

Lower the L10 so that the splay hook engages the degree pin, then insert a locking pin into the hole directly below the hook. The hook is now secured.

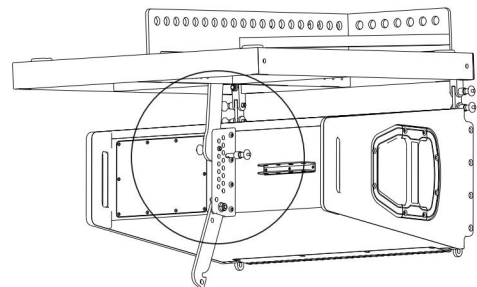
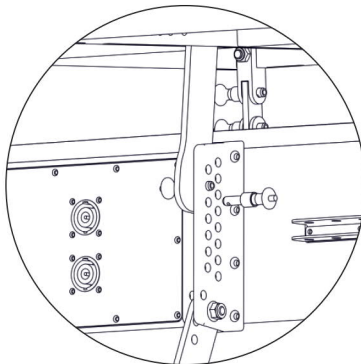

Follow the same procedure for each subsequent L10. Start with the front attachment.

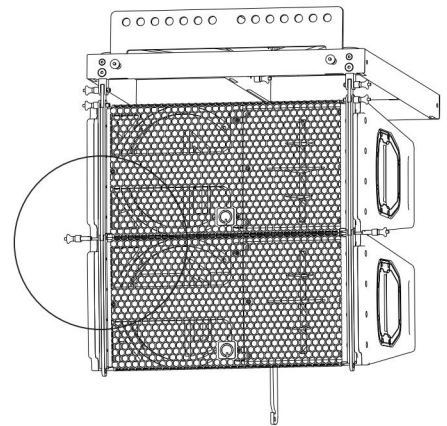
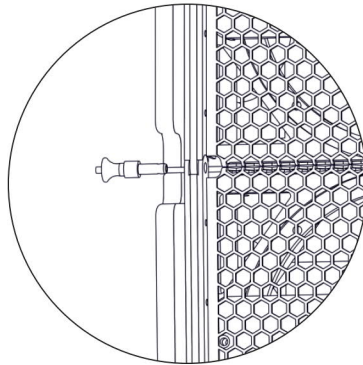

Again place the L-pin at the desired angle and lower the speaker into the splay hook.

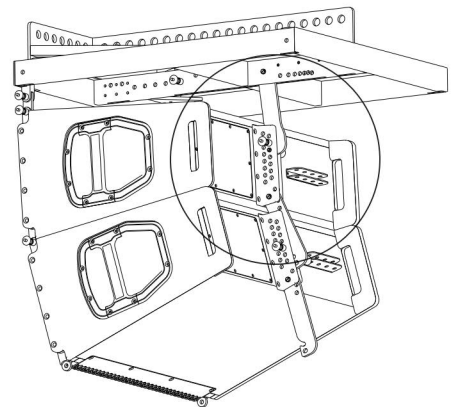
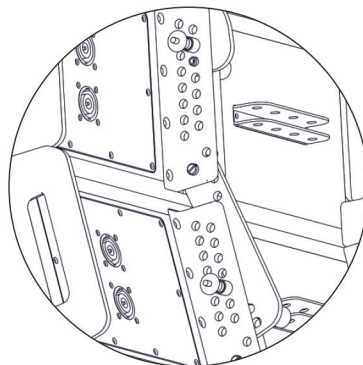

Again place the L-pin in the first hole under the corner pin to secure the splay hook.

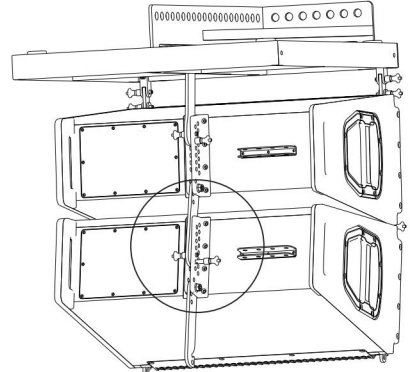
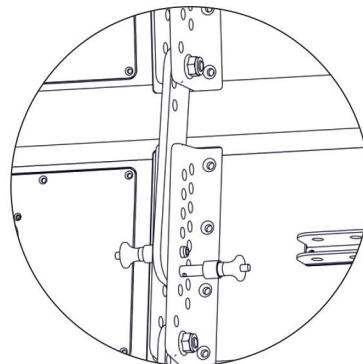

To make sure the splay hook of the bottom speaker is out of sight, you can rotate it upwards and park it with a locking pin.

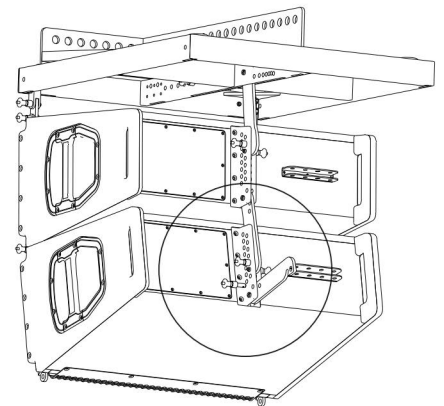
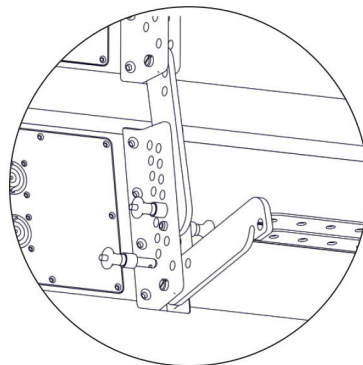

## The L10 rigging construction principle with C3

If you don't need to fly L-series subs or you don't need to stack L-series tops, instead of using the C1/C2 combination, you are quickest on your way with the C3. The C3 T-bar offers a simple and basic solution for flying arrays consisting of L-series tops only.

Except for the differences mentioned above, the C3 works basically the same way as the C1/C2 system. Also with C3 rigging the L10 is being handled as a so-called Tension Mode system in which the loudspeakers drop into a hook by their own weight during setup, after which they then are secured so the hook stays in place.

For transport, the hooks are unsecured so the speakers will gradually collapse at their maximum angle while lowering them into their trolley. (more about this further on in this manual)

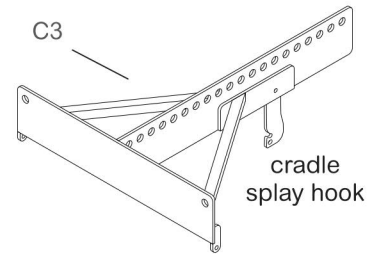

Attach the front of the L10 to the C3 cradle by inserting an L-pin through the L10 fitting on left and right front side of the L10.

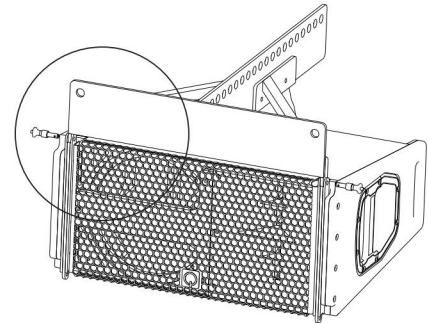
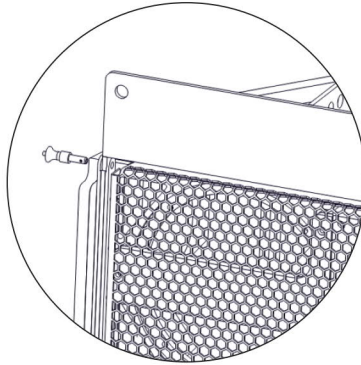

At the rear, place the first pin in the hole with the desired angle at which the L10 should hang from the cradle or the speaker hanging above it.

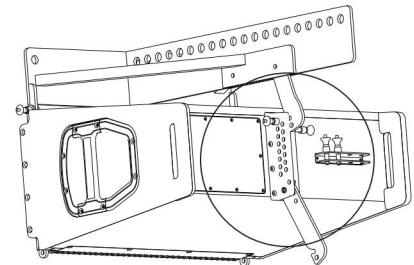
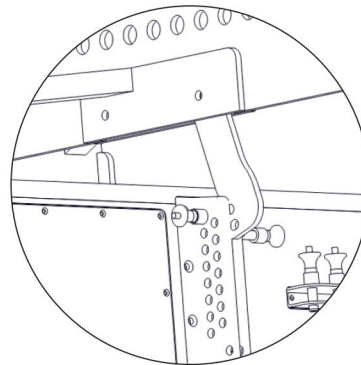

Lower the L10 so that the splay hook engages the degree pin, then insert a locking pin into the hole directly below the hook. The hook is now secured.

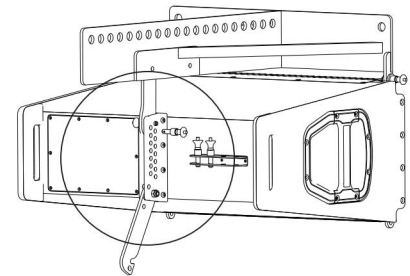
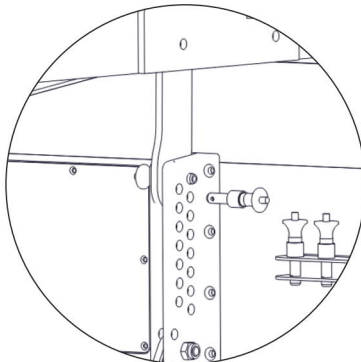

Follow the same procedure for each subsequent L10. Start with the front attachment.

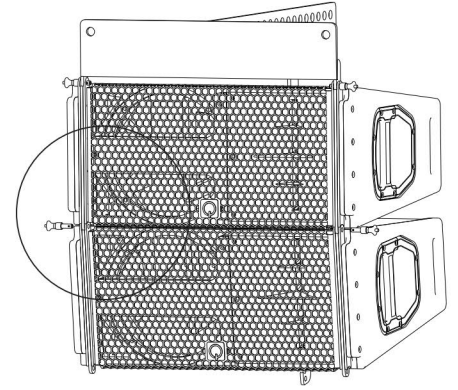
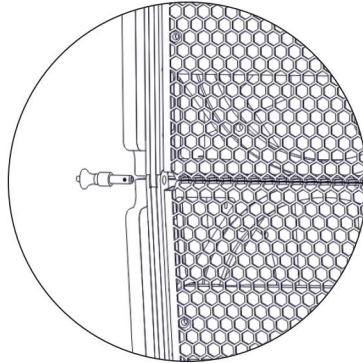

Again place the L-pin at the desired angle and lower the speaker into the splay hook.

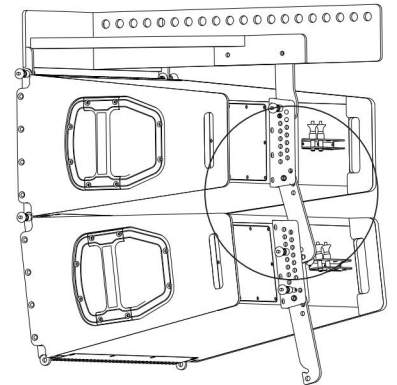
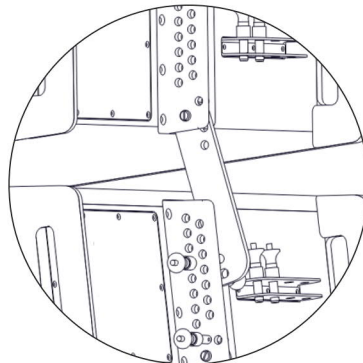

Again place the L-pin in the first hole under the corner pin to secure the splay hook.

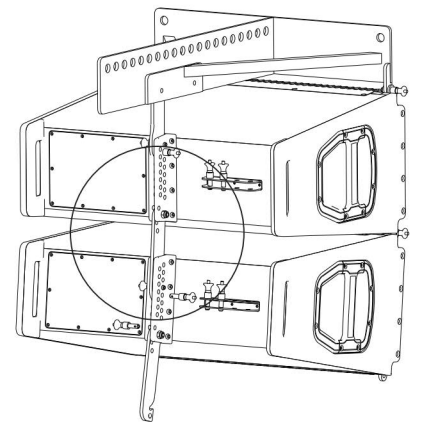
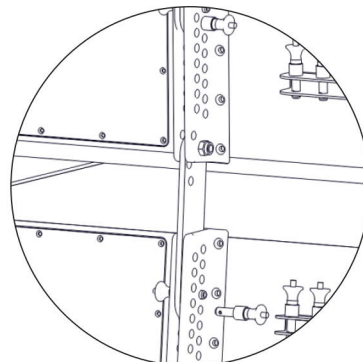

To make sure the splay hook of the bottom speaker is out of sight, you can rotate it upwards and park it with a locking pin.

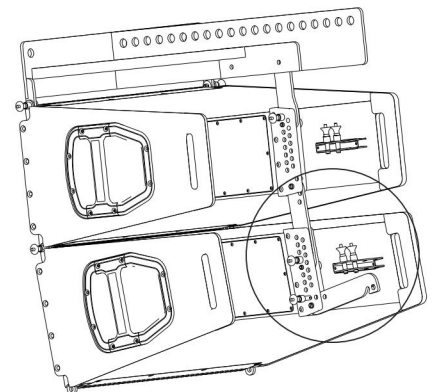
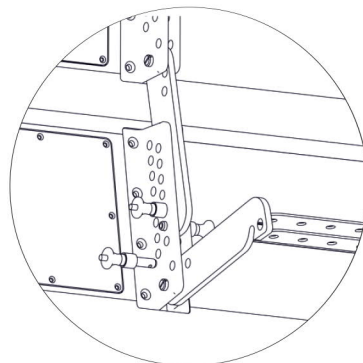

# L10

arrayable full range loudspeaker

## Picking up L10 rigs from a trolley

The easiest way to build, break down and transport a larger L10 array is to use the L1 dolly which fits 4 L10s and which also has room for a C1 cradle and C2 T-bar.

Attach the front of the L10 to the C1 cradle by inserting an L-pin through the E1 on both sides. The E1's on their turn have previously been attached to the C1 using the same pins, as well as the C2 T-bar.

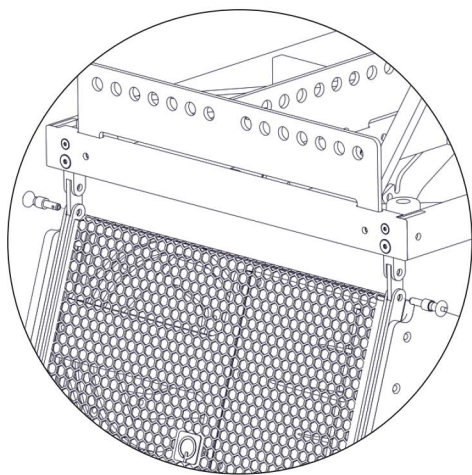

At the rear, for each loudspeaker, place the first pin in the hole with the desired angle at which the L10 should hang from the cradle or the loudspeaker hanging directly above it.

Note that the first hook is the one that is attached to the C1 cradle itself

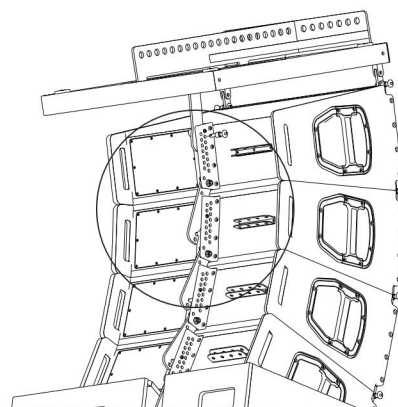
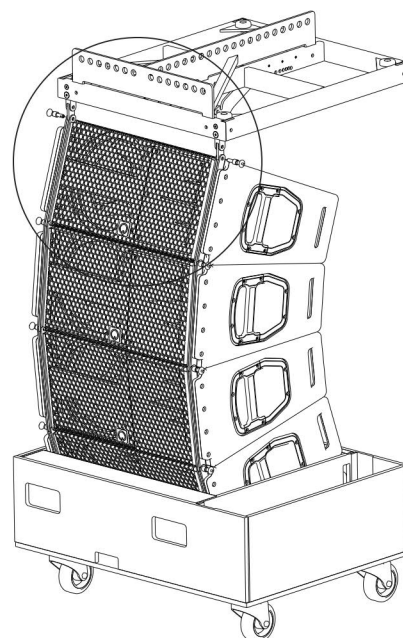
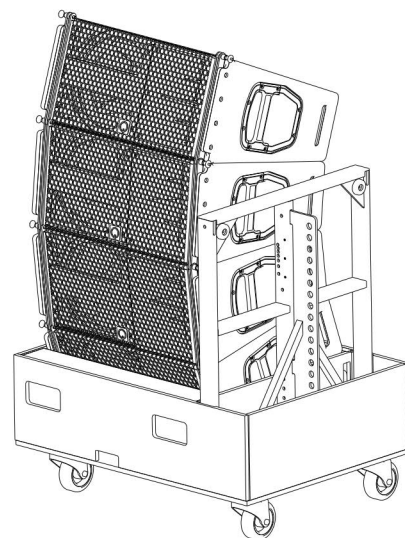
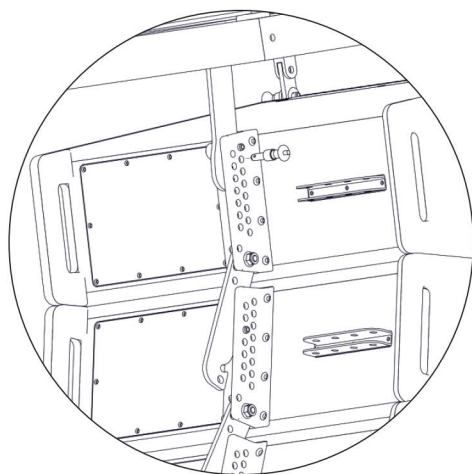

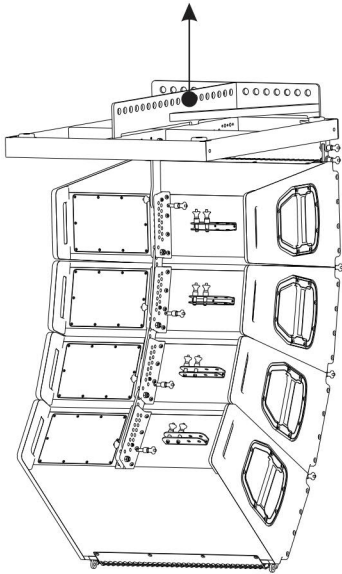

Adjust the angles, lift the rig so that the hooks fall into place and secure the hooks with L-pins.

Hoist the rig from its trolley and move the next trolley (if more than 4 L10's are desired) directly underneath.

Follow the interconnecting procedure for each subsequent L10. Start with the front attachment.

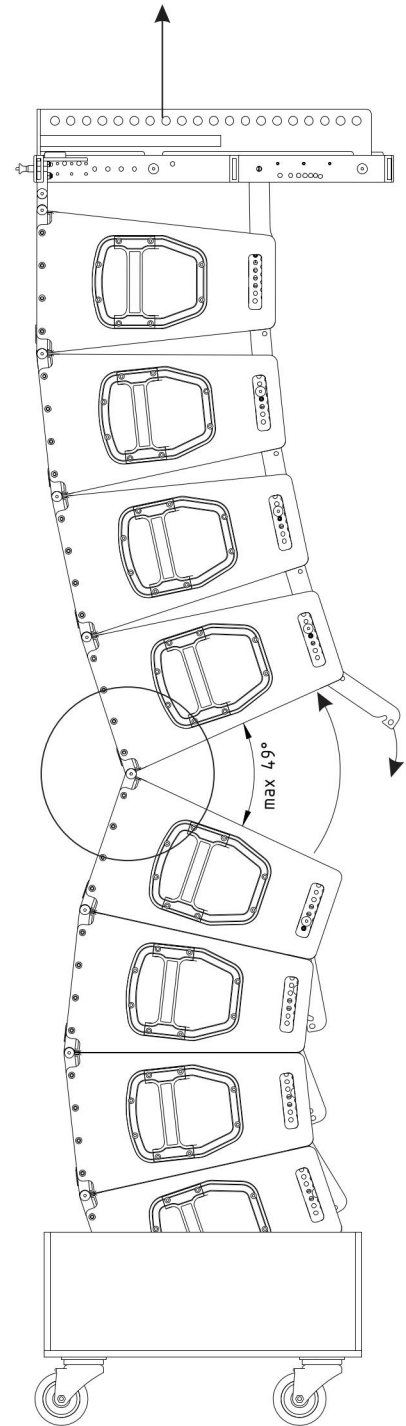
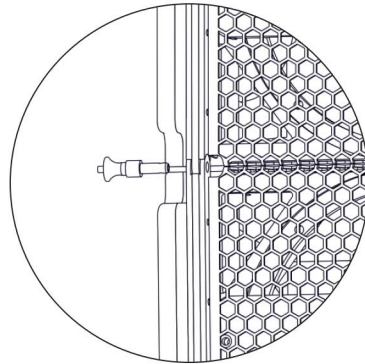

# L10

arrayable full range loudspeaker

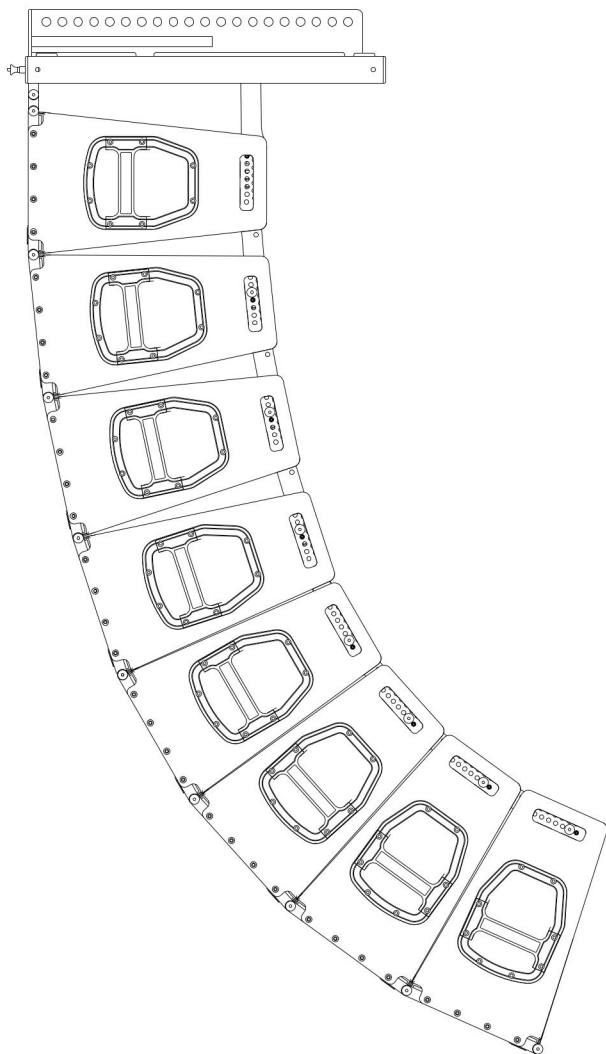

Hook up the front first with the L-pins and lower the rig again onto the loudspeakers that are on the trolley.

Then follow the same procedure as for the first 4 speakers (as shown on the left page and above). Adjust the angles, lift the rig so that the hooks fall into place and secure the hooks with L-pins.

This drawing shows how the back of the array should look when the array is hanging.

The hooks are at the pre-set angles and are all secured with locking pins in the hole directly below the corner pin in order to keep all hooks properly and safely in place.

In this case, all L10s are at their maximum angle to each other (12 degrees), but this can of course be any other desired angle.

Calculating the desired angles, the number of speakers required for the venue and determining the point of contact on the T-bar is explained in the chapter EASE Focus 3.

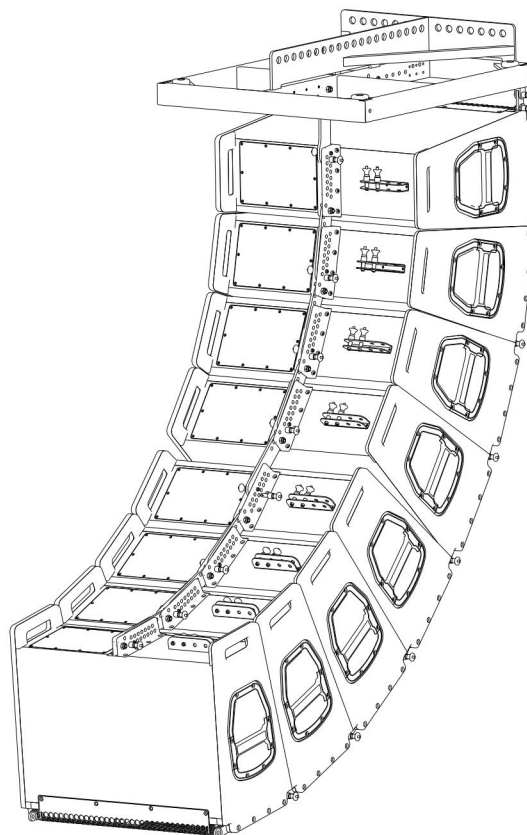



**L10 + sub rigging construction principle**

Flying or carrying a bass cabinet in an L10 array is done in exactly similar to flying L10 speakers only. The difference is that the C1 / C2 cradle has to be mounted directly on top of the first flying bass cabinet while a subsequent C1 cradle is mounted under the bass cabinet onto which the L10s can be flown.

If necessary, more bass cabinets can be mounted underneath each other first without the need for an extra C1 cradle.

The bass cabinets have extendable spoons (which are held in place by a spring when not in use). The C1 cradle or a subsequent bass cabinet can be attached to these extendable flails.

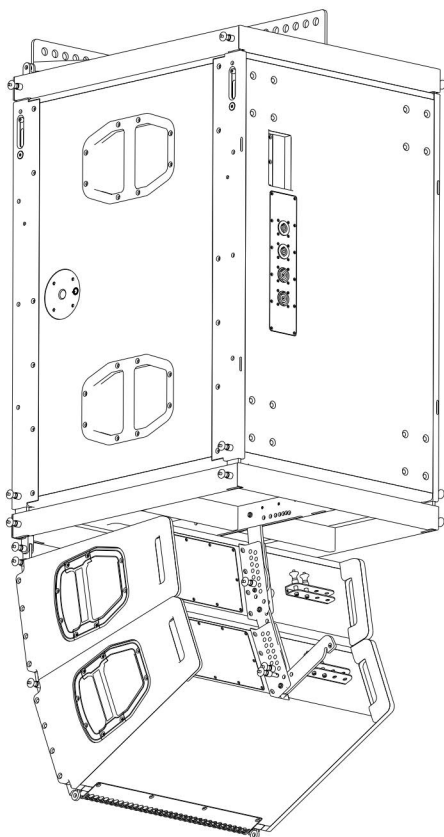
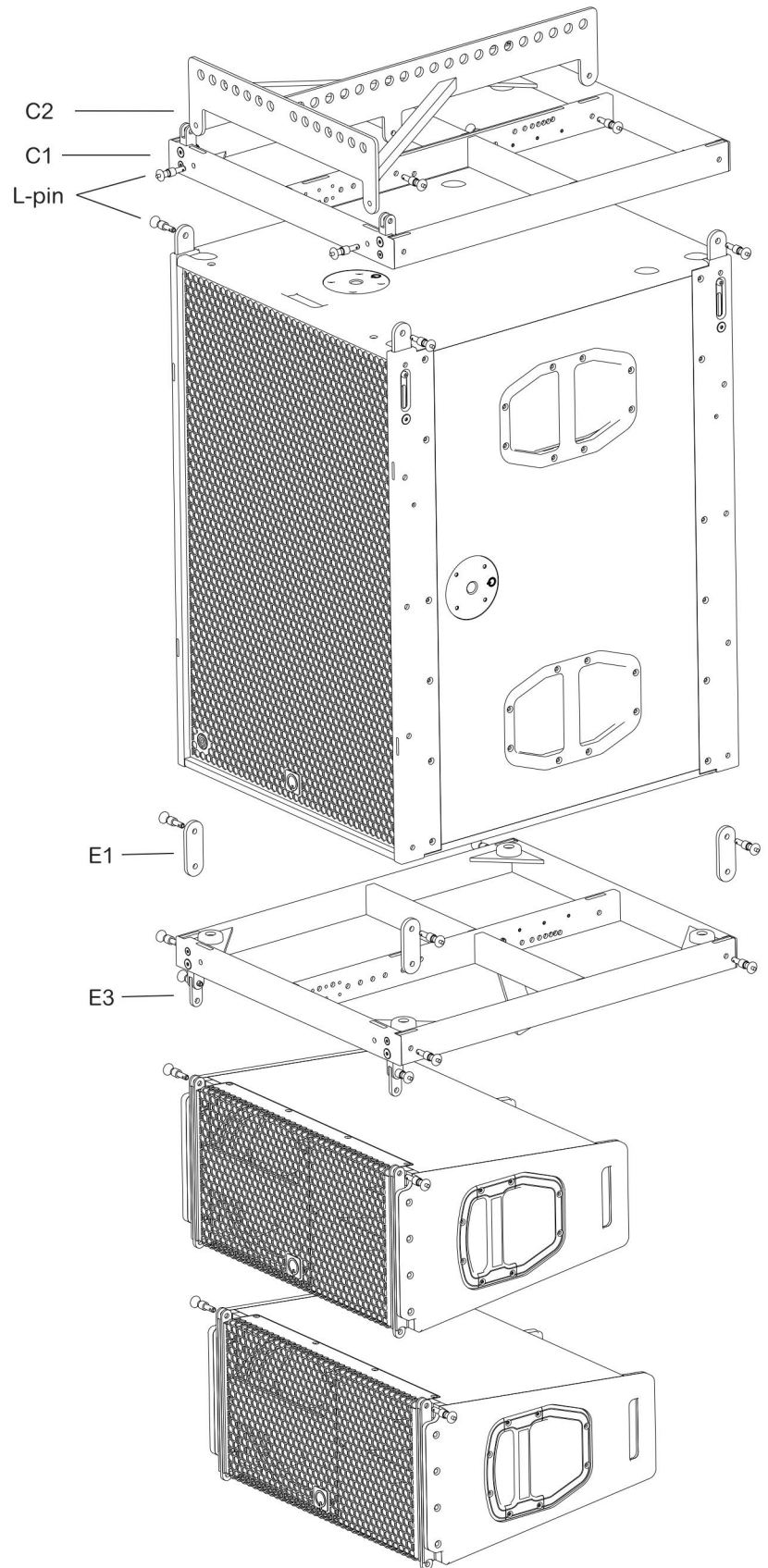

## Stacking L10 with the C1 combi frame

Mount the C1 cradle in its 'stacking' position on the bass cabinet with the extendable rigging palls of the bass cabinet and the L-pins.

Then install the first L10 in the front fixings and secure it with an L-pin on each side.

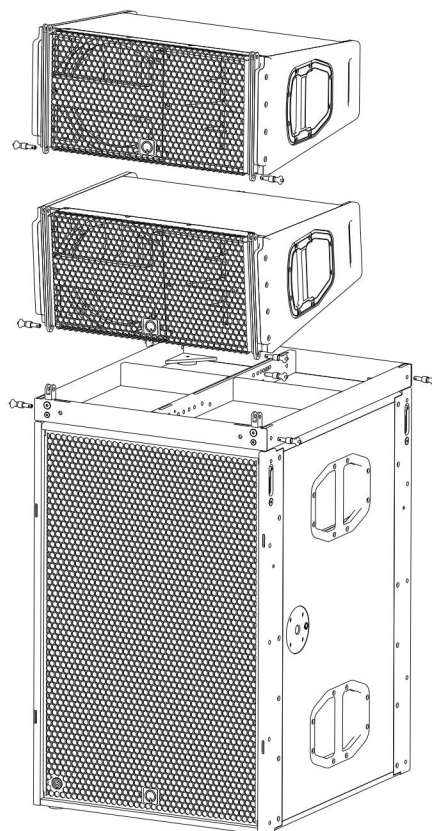

The drawing below shows a cross section of the middle bar of the C1 cradle. Clearly visible is the splay hook of an L10, fitting into the cradle in a detented receiver which makes setting the desired angle of the L10 very easy.

After placing under the correct angle, only a locking pin has to be placed and the L10 is secured to the bass cabinet.

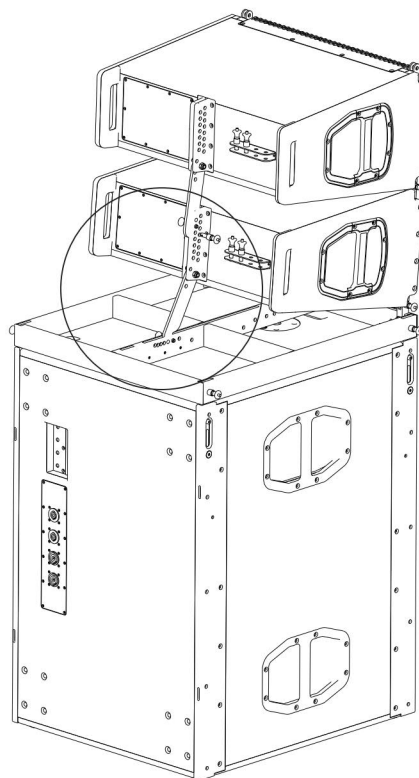
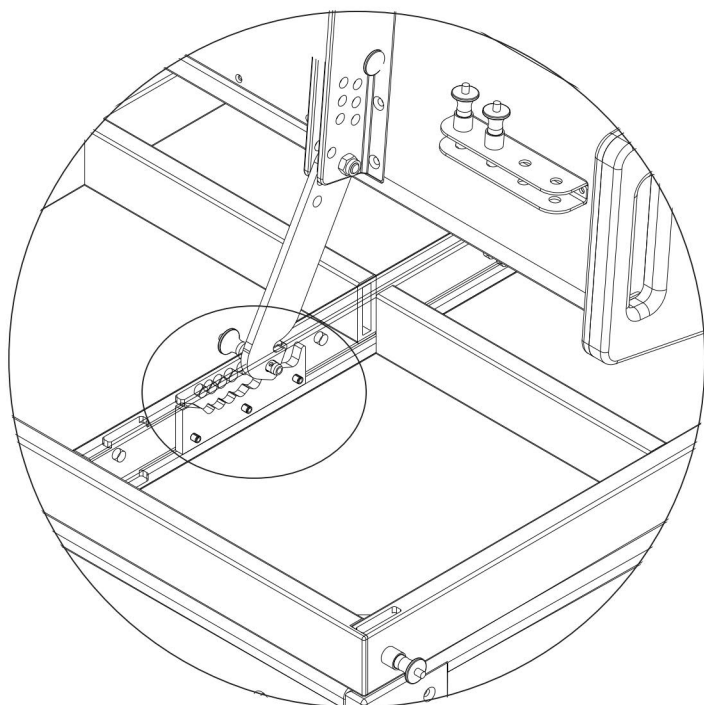

**Sample setups**

On the pages hereafter some sample setups are given. Wiring is on the left page while cabling is on the right page. The proposed setups are just examples, of course many other setups are possible and ways of wiring and cabling. Of course this only concerns examples. After all, there are many ways in which the system can be configured, wired and cabled.

As for the impedance; we strive for a minimum impedance of approx. 4 Ohms, the amplifier used (A42) however can also be loaded very well at 2 Ohms.

Below are the products used for the setups.

ordercode	model	description
550000	L10-L	10"/2x1" Biamped arrayable system / left version
550001	L10-R	10"/2x1" Biamped arrayable system / right version
550102	L10-C1	L-Coupler
550202	L10-C2	C2 T-bar for C1
550302	L10-C3	C3 T-bar for L10 tops
550103	L10-E1	Bass cabinet interlink for C1
550105	L10-E3	Top cabinet interlink for C1
604200	A42	4x 2000 W/8 Ohms Class-D Amplifier

For more L-series products and other quint audio models, please check our website: [www.quintaudio.com](http://www.quintaudio.com)

**L10 (550000 L 550001 R)**  
 / 10 Ohms  
 recommended:  
 3 per dual channel (bi-amped)  
 (4 optional)

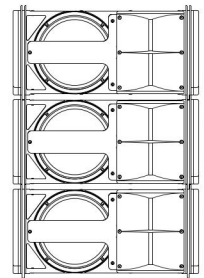

**P44 (TBA)**  
 4x4 touring processor  
 single and dual setup  
 possible in 19"/2U

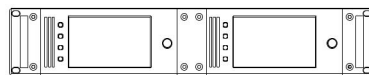

**L-sub (551000) / 4 Ohms**  
 recommended:  
 1 per channel (2 optional)

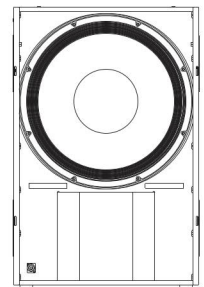

**A42 (604100)**  
 4x2000W / 8Ohms  
 SMPS Power Amplifier  
 19"/1U



**L-low (552000) / 4 Ohms**  
 recommended:  
 1 per channel

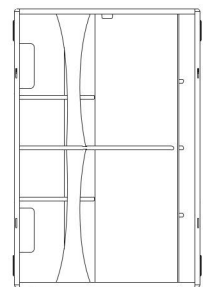

NL8 CABLE



NL8 TWIST CABLE



NL4 CABLE



NL4 TWIST CABLE



**L-bass (553000) / 4 Ohms**  
 recommended:  
 1 per channel

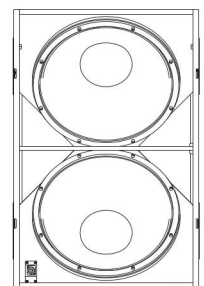

## Example L10 setups

This setup represents an example of a small powerful dual channel live-sound ground-stacked PA system, consisting of 8x L10, 2x L-low and 4x L-sub, making use of only 1 pc. of 4-channel P44 processor and 2 pcs. of A42 amplifiers. The amplifiers are driven into a 2 Ohms load for the L-Subs.

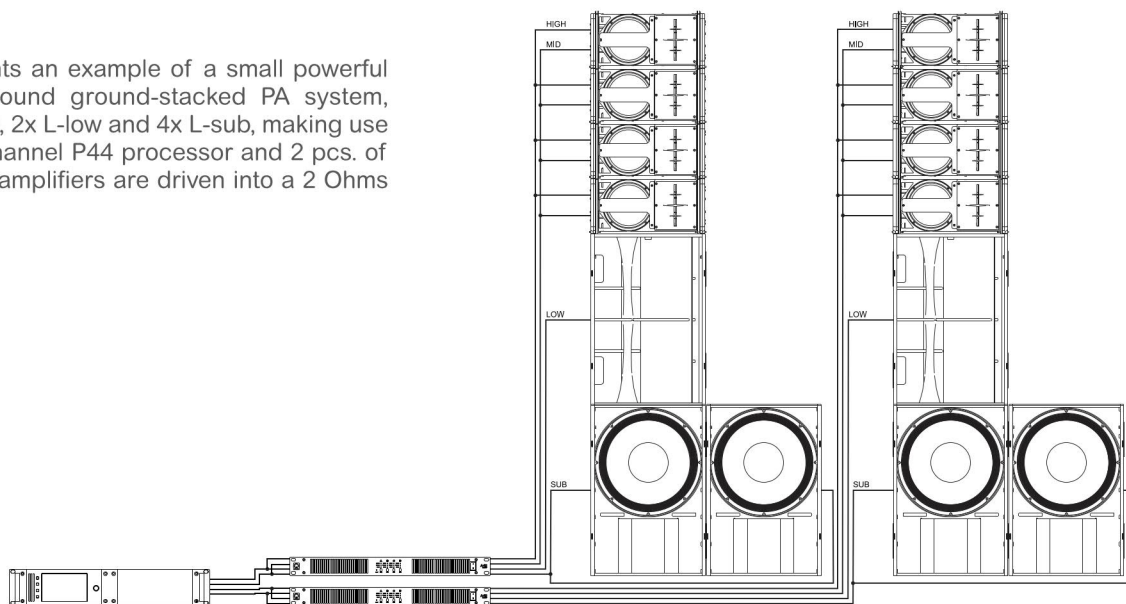

## Wiring

This setup represents an example of a small powerful single channel dance-stack, consisting of 6x L10 and 4x L-bass, making use of 1 pc. of a 4-channel P44 processor and 2 pcs. of A42 amplifiers. The A42's are driven on a 2 Ohms load for the L-bass's.

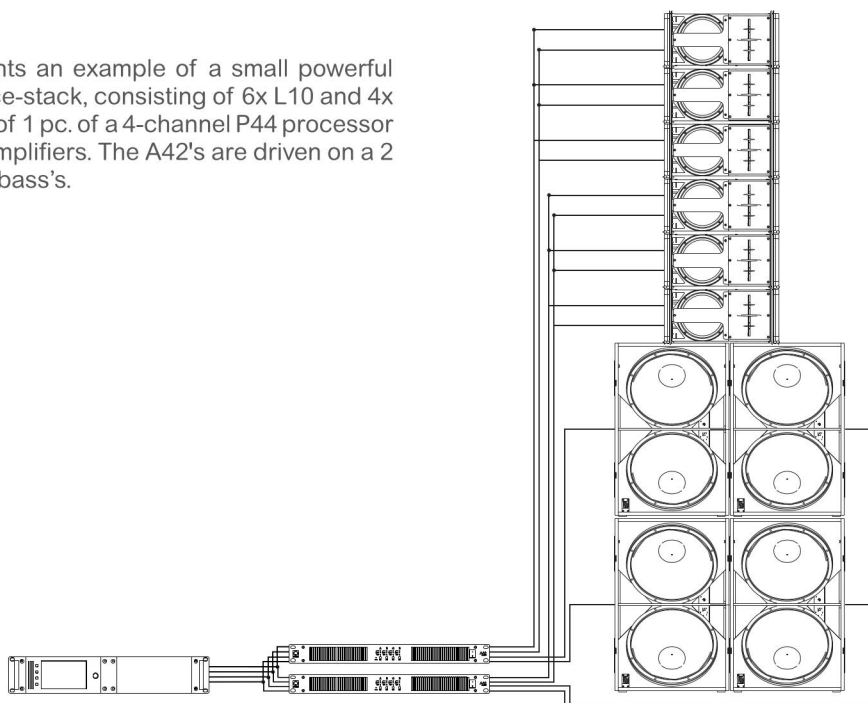

### Cabling

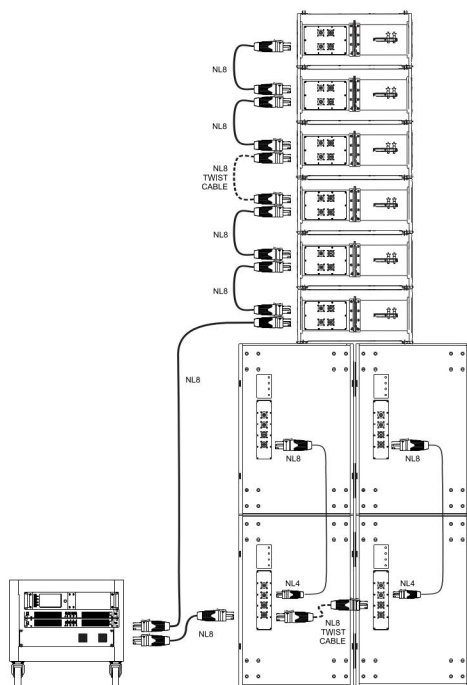
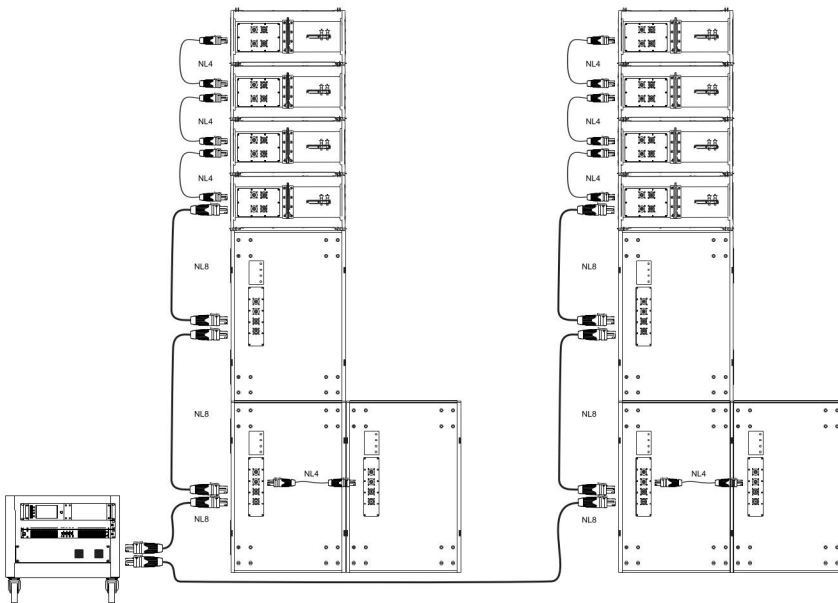

## Example L10 setups

## Wiring

This setup represents an example of a compact dual channel flown speech and background music PA system in full-range mode, consisting of 12x L10, making use of one 4-channel P44 processor and 2 pcs. of A42 amplifiers.

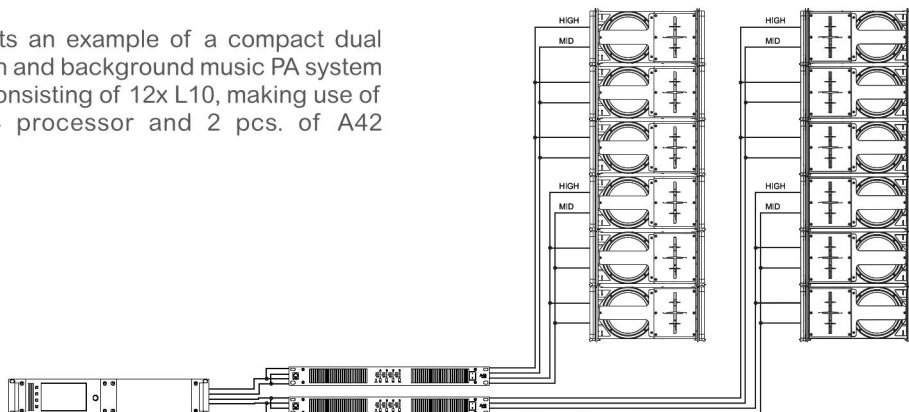

This setup represents an example of a single channel flown live theatre PA system with ANC (Active Noise Cancelling) bass loudspeakers. The system consists of 9x L10 and 2x L-bass, making use of one 4-channel P44 processor and 2 pcs. of A42 amplifiers.

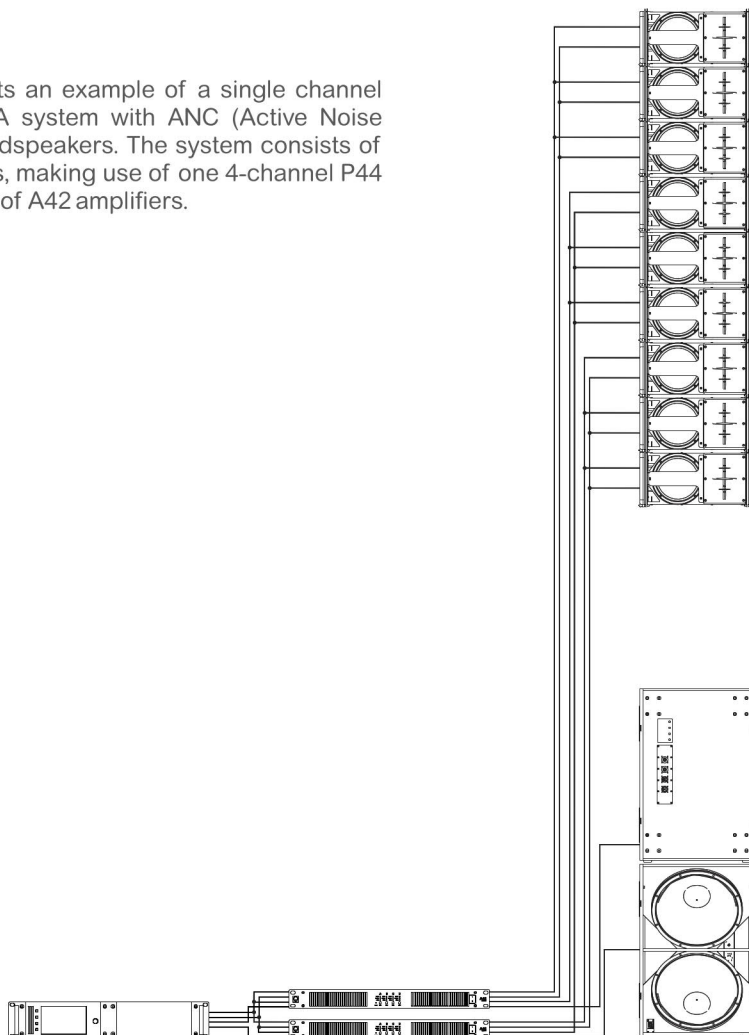

### Cabling

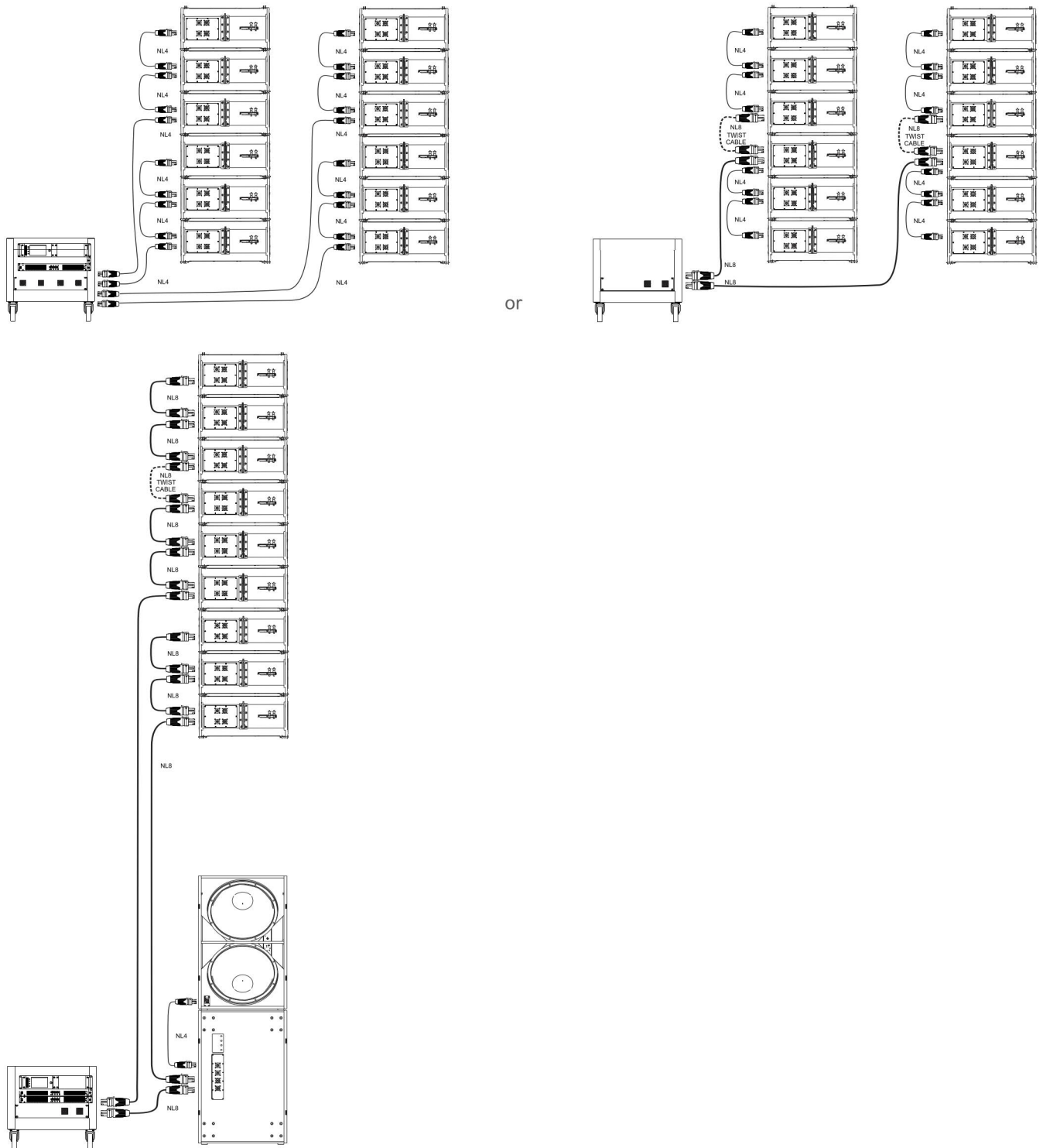

## Example L10 setups

This setup represents an example of a performance based mid-sized venue single-channel flown live sound PA-system, consisting of 12x L10, 4x L-low and 8x L-sub, making use of one 4-channel P44 processor and 4 pcs. of A42 amplifiers. The L-low's are flown next to the L10-array in order to support a strong, phase coherent, well defined mid-low area in your powerful sound image.

## Wiring

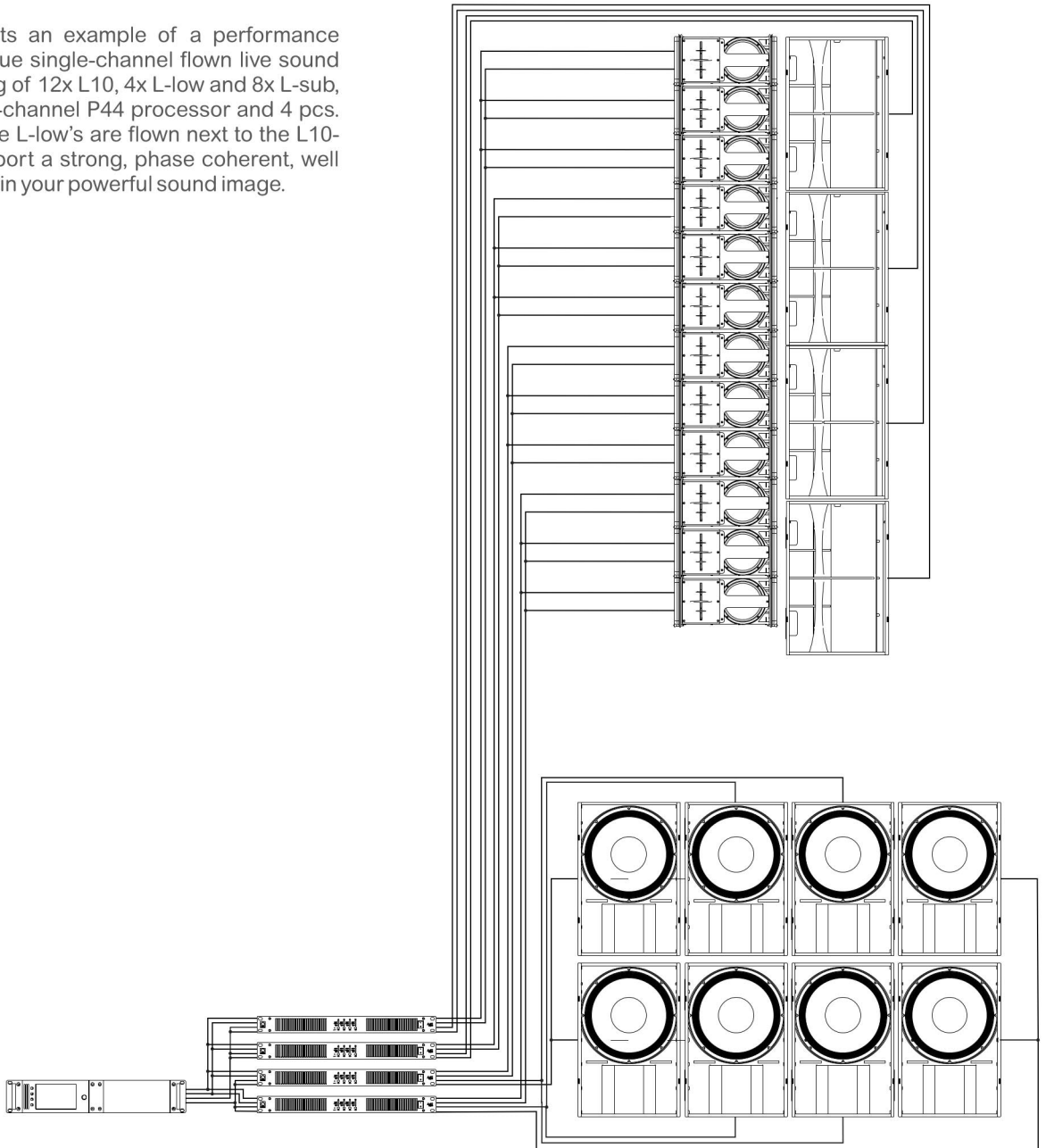



### Cabling

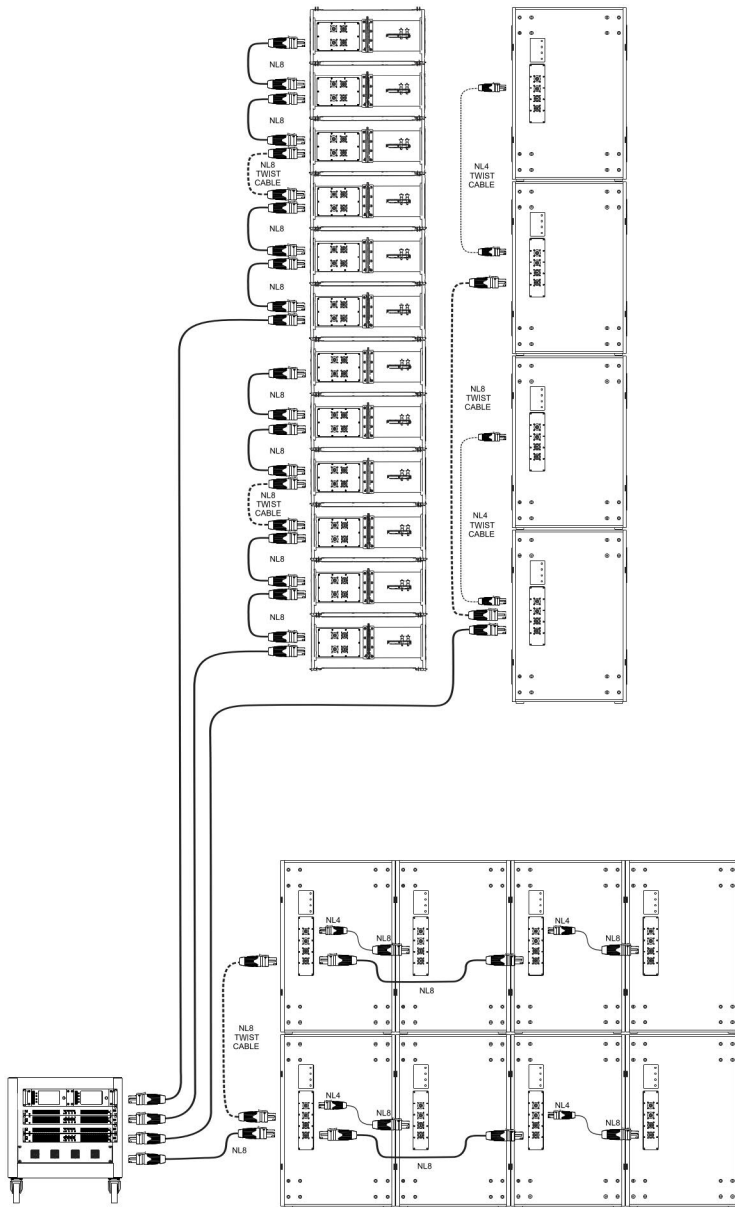

## EASE Focus 3 - Universal Sound System Modeling in 3D

With Quint Audio's proprietary EASE Focus 3, system designers can simulate the acoustical performance of the entire sound system to find the optimal setup for a given venue with multiple audience areas, curved and inclined seating. EASE Focus 3 assists the user with many intelligent features such as auto splay functions, Virtual EQ, and detailed analysis of sound coverage, SPL and frequency response. The software is available as a free download from the Quint Audio website and from <https://focus.afmg.eu/index.php/fc-downloads-en.html>

EASE Focus 3 is the universal tool for the simulation of loudspeaker systems. It is supported by nearly many major loudspeaker manufacturers and offers a comprehensive set of features from general design functions for venues and sound systems all the way to specialized tuning and optimization features.

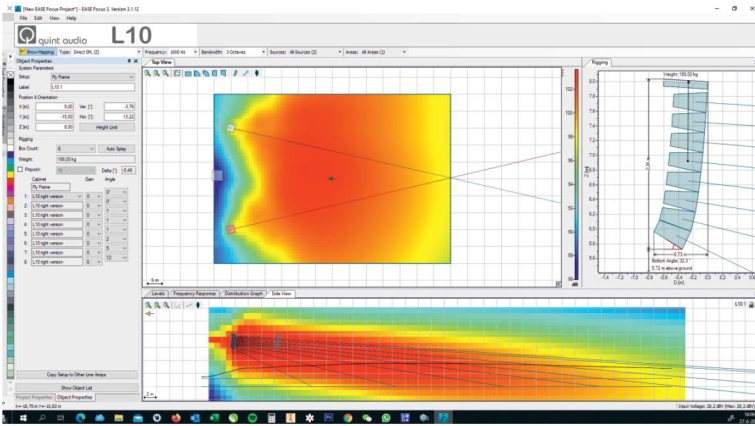

You can quickly enter a venue into EASE Focus 3 using differently shaped basic audience zones and define multiple audience areas within these. Areas can be placed at different heights and can have inclining seating. Geometry data can either be entered from an existing plan using regular X, Y, Z coordinates or by use of polar coordinates as derived from laser distance and inclinometers on site. Add additional vertical cutting planes to provide section views for extended evaluation.

You can add sound systems from the EASE Focus' encompassing database. EASE Focus 3 supports line arrays, configurable loudspeakers and columns, typical point sources, and subwoofer arrays. Each sound source can be tweaked and adjusted in placement, orientation, and electronic parameters such as gain, polarity, delay, and a virtual EQ. Up to 40 sound sources, even from different brands, are supported within one project. Nifty functions for stacking, snapping, moving, and copying make the setup of larger systems easy.

EASE Focus immediately calculates and shows the sound coverage on your audience zones and section including the splay angles between the adjacent cabinets. You can investigate the interaction between separate sound sources especially in the low and low-mid frequency range with the "Complex Summation" feature introduced with EASE Focus 3.

**EASE Focus 3 - Universal Sound System Modeling in 3D**

- Simulate line arrays, column speakers, point sources, and sub arrays
- Define audience areas, section views, and receiver locations flexibly
- Calculate sound coverage and frequency response immediately
- Use systems of different manufacturers within one project
- Use FIRmaker optimization to compute FIR Filters tailored to the venue

With EASE Focus 3, system designers can simulate the acoustical performance of the complete sound system to find the optimal setup for a given venue with multiple audience areas, curved and inclining seating. Focus 3 assists the user with many intelligent features such as Auto Splay functions, Virtual EQ, and detailed analysis of sound coverage, SPL and frequency response.

EASE, FIRmaker and AFMG are registered trademarks of AFMG Technologies GmbH.

All mappings clearly show the influence of polarity, phase, and propagation delay of your systems on the audience areas. Adjust your settings and re-calculate in order to maximize SPL and minimize negative effects.

The "Complex Sum" calculation setting allows effective simulation and tuning of basically any arrangement of subwoofer arrays. Place and stack your loudspeakers freely or insert a pre-configured array. Then tune them to deliver the desired radiation pattern. While inserting a new sound source you may specifically add subwoofers as a subwoofer array. EASE Focus 3 treats such an array as a single sound source, offers different parameters to conveniently configure it, and automatically computes suggested delays. EASE Focus provides high accuracy in the full frequency range from 20 Hz to 20 kHz due to the high internal data resolution and the GLL data format. Compatible data structures allow data exchange with EASE and other AFMG software packages. Fully configured line arrays can be exported for further use in EASE. Digitally steered columns and other configurable loudspeakers require an additional proprietary DLL that can provide beam steering filters and other manufacturer-specific settings.

EASE Focus currently supports German, English, Spanish, Italian, Portuguese, and French languages.

**Warranty**

Quint Audio BV warrants the original purchaser and any subsequent owner of each new Quint Audio BV product, for a period of 5 years limited from the date of the original purchase by the original purchaser that the new Quint Audio BV product is free of defects in materials and workmanship. Quint Audio BV warrants the new product regardless of the reason for failure, except as excluded in this warranty. In order to obtain warranty, you must keep the original sales receipt to establish the exact date of purchase.

Warranty does not cover any product which has been damaged because of any misuse, accident, or negligence. Warranty also does not extend to a new Quint Audio BV product if the serial number has been defaced, altered or removed.

Quint Audio BV will replace defective parts and repair malfunctioning products, regardless of the reason for failure (except as excluded). Warranty work can only be performed at our authorized service centres, or at our factory.

**Disclaimer**

Quint Audio BV is not liable for any damage to loudspeakers, amplifiers, or any other equipment that is caused by negligence, misuse or improper installation.

Quint Audio BV is not liable for any incidental damages resulting from any defect in the new Quint Audio BV product. This includes any damage to another product or products resulting from such a defect.

The information contained in this manual has been carefully checked for accuracy, at the time of going to press, however no guarantee is given with respect to the correctness.

Quint Audio BV bv accepts no responsibility for any errors or inaccuracies that may appear in this manual or the products and software described in it.

Technical specifications, dimensions, weights and properties do not represent guaranteed qualities.

Quint Audio BV reserves the right to change specifications without notice.

# 5

**years limited warranty**

## EC declaration of conformity

This declaration applies to the product Quint Audio model L10. All product variants are included, provided they correspond to the original technical version and have not been subject to any later design or electro-mechanical modifications.



We, Quint Audio BV herewith declare that said products are in conformity with the provisions of the following EC directives including all applicable amendments.

States that the following products:  
L10 rigging system is in conformity with the provisions of the following EC directives and applicable amendments:

Machinery 2006/42/EC and the national laws to enforce this directive, National standards and technical specifications applied: DIN EN ISO 12 100, DIN EN 1050, BGV C1 provided the mounting components are unaltered/modified and in "factory-original" condition.

Established at Wintelre, the Netherlands Aug 1th, 2019 A detailed declaration is available on request and can be ordered from Quint Audio BV.

## WEEE Declaration (Disposal)

Electrical and electronic equipment must be disposed of separately from normal waste at the end of its operational lifetime.



Please dispose of this product according to the respective national regulations or contractual agreements. If there are any further questions concerning the disposal of this product please contact Quint Audio BV.

## Copyright © 2020

Quint Audio. All rights reserved.

Except as permitted by applicable copyright law, no part of this publication may be reproduced, stored in a retrieval system, or transmitted, in any form or by any means, electronic, mechanical, recording or otherwise, without prior written permission from Quint Audio BV.

L-series is an alpha numeric designation for Quint Audio BV products and accessories are trademarks of Quint Audio BV.

All third-party trademarks mentioned herein are the property of their respective trademark holders.

Printed in the Netherlands

## INDEX

2	Unpacking
3 - 5	Safety instructions
6	Design
7	Applications
8	Connectors / Internal wiring
9	Rigging accessories
10 - 11	Rigging principles C1/C2
12 - 13	Rigging principles C3
14 - 16	Flying multiple L10's
17	Flying subs
18	Stacking
19 - 25	Sample setups
26	Simulation software
27	Warranty
28	CE
28	WEEE